



Assembly Notes

Before you start building your kit, please take time to read the manual in full at least once to enable you to fully understand the procedures and avoid any mistakes. The following notes are important and should be read.

Disclaimer:

1. Audion supplies this product as a kit of parts for self-assembly, and the construction is entirely at your own risk. No warranty or responsibility will be accepted or applied; any injury or damage will be the responsibility of the assembler. The kit of parts does not constitute a finished product in any way.
2. When wiring the mains sockets, switches, and mains transformer the attaching wires should all be tinned and wrapped where possible before being soldered. This ensures that wires are not held on to terminals purely by solder alone and safeguards them against becoming loose.
3. When wiring an audio amplifier it is a good idea to wire each channel of the amplifier symmetrically to keep all signal and power paths similar in length.
4. **Warning:** Extreme care should be taken when testing the amplifier as it will need to be switched on with the cover panels removed. Unless you are completely familiar with electronics and the circuit layout of the amplifier, it is best to assume that ALL connections are of very high voltage and can at the very least cause serious injury.
5. This kit is intended for assembly only by adults who have a good understanding of electronics and electronic construction. Please note - all valves in the finished product get very hot in normal operation; care must be taken to protect yourself and children by avoiding contact with them.

This valve amplifier kit has been designed to be configurable by the assembler. The kit can be set-up to work in either Push-Pull (PP) mode delivering approximately 30 Watts per channel, or Parallel Single-Ended (PSE) mode delivering approximately 20 Watts per channel. The argument to using the lower powered PSE mode is improved sound quality in the mid and upper ranges. PP on the other hand will drive less efficient speakers and offer a faster bass line. The assembler must therefore decide which way to build the amplifier to save making unnecessary changes later. If the amplifier is intended for use in PSE mode, extra components can be purchased to reduce hum levels in the power supply (this is not a requirement but may assist S/N ratios on some sensitive speakers).

Opening Your Kit And Checking its Contents

Please note that a mains lead is NOT supplied with this kit due to safety regulations in the country of its intended use. You will need to purchase an I.E.C. fused mains lead with a 5-amp fuse fitted in the plug.

Bill of materials for the **Edison 60** kit:

- 1 x Bottom chassis panel
- 1 x Bottom cover plate
- 1 x Front chassis panel
- 2 x Side panels – left and right
- 1 x Top panel
- 4 x EL34 valves
- 4 x 6922/ECC88/E88CC/6DJ8 valves or equivalent
- 2 x Audio PCB's
- 1 x Toroidal type mains transformer with mounting kit (M5 x 80 washer plus M5 x 80 bolt + nut)
- 2 x Output transformers

The **power supply** pack contains:

- 1 x Power supply PCB
- 4 x 220uF 250V electrolytic capacitors (C7,C8,C14,C15)
- 4 x IN4007 rectifier diodes (D1,D2,D3,D4)
- 4 x 523K or similar high value resistors (R19,R20,R33,R34)
- 1 x 100R 7W resistor (R35)
- 3 x M3 X 30mm hexagonal metal stand-offs
- 6 x M3 screws
- 6 x PCB terminal pins

The **assorted hardware** pack contains:

- 1 x Volume knob
- 1 x 50K LOG potentiometer (volume)
- 4 x EL34 Octal 8-way valve bases (for V1 and V2)
- 3 x RCA input sockets pairs
- 1 x Mains switch
- 1 x Fused mains socket
- 1 x Fuse holder
- 1 x T3.15A 250V fuse (Note: 'T' denotes slow-blow)
- 2 x SPDT switches
- 6 x Red speaker terminals
- 2 x Black speaker terminals

The **audio PCB** pack contains (2 off per kit):

- 2 x 6922 9-way valve bases (for V3 and V4)
- 4 x 0.33uF/0.47uF 630V signal capacitors (C1,C2,C10,C13)
- 2 x 22uF 450V Axial electrolytic capacitors (C5,C6)
- 2 x 47uF 100V Axial electrolytic capacitors (C3,C4)
- 2 x 100uF 25V Axial electrolytic capacitors (C9,C12)
- 2 x 470R 5W wirewound resistors (R30,R31)
- 1 x 8K2 3W resistor (R18)
- 4 x 47K 2W resistors (R6,R7,R8,R29)
- 1 x 374R 2W resistor (R25)
- 1 x 15K resistor (R17)
- 7 x 1K resistors (R9,R10,R11,R11b,R12,R21,R22)
- 1 x 261R resistor (R28)
- 3 x 576K resistors (R2,R3,R26)
- 2 x 249K resistors (R4,R5)
- 1 x 75K resistor (R24)
- 1 x 470R resistor (R27)
- 1 x 100R resistor (R14)
- 1 x 61.9K resistor (R1)
- 1 x 68K resistor (R23)
- 1 x 16.2K resistor (R13)
- 13 x PCB terminal pins

The **screws and fittings** pack contains:

- 4 x Mounting feet
- 1 x M5 X 80mm washer and nut
- 8 x M4 washers
- 12 x M4 screws with nuts
- 8 x M3 X 12mm hexagonal metal stand-offs
- 1 x Earth tag
- 8 x M3 screws black
- 34 x M3 screws plain
- 10 x M3 nuts
- 4 x M3 countersunk screws

The **wire** pack contains:

- 1.4m screened input cable
- 2m of red wire
- 2m of blue wire
- 2m of green wire
- 2m of black wire
- 4 x cable ties
- 4 x 105R wirewound resistors
- Short length of heat-shrink sleeving

The **Edison 60 Plus** kit contains the following as extra to the above:

- 1 x Power supply pack (detailed above)
- Stainless-steel mirror-finished top cover (as seen in the photo on the kits home page).
- 1 x Toroidal type mains transformer with mounting kit
- 1 x Chrome and black volume knob

Tools Required:

A good set of tools makes assembly easier although the following tools are required:

Small flat blade screwdriver

Medium sized crosspoint screwdriver

Multimeter capable of measuring voltages in excess of 500V

Cutters – Side/Snip

Pliers – Round/Snipe Nose

Universal wire strippers

Soldering iron 25W or higher

60/40 Solder 18-22 Swg

Selection of small metric spanners

Audio PCB Assembly Instructions:

On the main PCB mount resistors R6, R7, R8, R29, R18, R30, and R31 approximately 7mm above the board, as well as R52 if you are configuring the amplifier for PSE mode. Resistors R6 & R7, and R8 & R29 should also be separated apart from each other by approximately 7mm. If the volume pot is being used then leave out resistor R1. Resistor R17 must be mounted on the reverse side (track side) of the board by approximately 5mm, although it is a good idea to fit this when the small valve bases are soldered in place.

There are two positions for resistor R11, either R11 or R11b, depending on whether the amplifier is to be used in PP or PSE mode. To make it easier to change between either mode do not put the 1K resistor in R11b, but stand it up so that one leg of the resistor goes to the top of C2, and the other goes to the track that links to point X13. Resistor R11 should be put in as well. If this is done the PCB will be set up for both PP and PSE, and will not need to be changed. Now go through the parts list and solder in the remaining resistors and capacitors. Note: when placing the electrolytic capacitors be sure to insert them paying attention to polarity. The signal capacitors C1, C2, C10, and C13 are not polarized. Bend resistors R30 and R31 away from capacitors C3 and C4, as the resistors may warm up after prolonged use.

Strip a length of any of the thin coloured wire supplied, and link points P1 to P10, although P10 must be connected on one board only as connecting both will result in a ground loop. There is an extra link on each main board that is not marked, which links pins 8 and 9 on valve base V3, to pin 3 on V3.

Solder the terminal pins in holes X1 to X13. The PCB's have holes for two different types of valve base, so the small valve bases V3 and V4 must be soldered in the **opposite side of the board from the components**, in the larger holes. It is quite important to keep them square (parallel) to the circuit board when soldering so that they align into the front chassis panel properly.

Power Supply PCB Assembly Instructions:

Insert and solder resistors R19, R20, R33, and R34, as well as diodes D1 to D4 observing their polarity. Solder R35 approximately 7mm above the board. Solder the terminal pins X15, X16, X17, and X18. Lastly, solder in the four electrolytic caps C7, C8, C14, and C15 observing the correct polarity.

IT IS A GOOD IDEA TO THOROUGHLY CHECK THE CIRCUIT BOARDS FOR ANY SOLDER JOINTS THAT HAVE BEEN MISSED OR LOOK DRY, AS THIS COULD CAUSE A LOT OF PROBLEMS LATER.

Assembly Of The Bottom Chassis:

Fit two of the mounting feet in the holes nearest the back of the chassis using an M4 screw and nut for each one - please note, the chassis panels may need drilling out to allow the M4 screw to fit. Fit the loudspeaker terminals, three red and one black on each side of the chassis; for ease of wiring fit the black terminal on the left of each set when viewed from the front. Mount the three pairs of RCA input sockets to the chassis with M3 screws and nuts; Note: the white sockets are for the left channel and should be mounted at the top. Push in the mains switch, and the mains socket with the fuse at the bottom.

When fitting any output transformer scrape the varnish off its underside, and the paint from the chassis to ensure a good grounding in at least one screw hole position. Now fit the transformers with M4 screws and nuts. The solder terminals on the output transformers should point towards the front of the amplifier.

Fit the mains transformer with a large insulating pad either side, and the large metal disc on the top secured with the long M5 bolt and nut. It is important to mount the mains transformer so that the wires point towards the front of the amplifier to avoid inducing mains hum into the output transformers; leave a little play in the length of its wires. Note: do **not** over-tighten the transformer as this may crush the windings and destroy it – you have been warned!

Finally, fit the complete power supply board using the three M3 stand-offs and M3 screws. There are three positions the board could go in, the easiest for wiring being the middle position.

Connect the loudspeaker terminals to the output transformers. The black speaker terminal goes to B1 as well as ground; leave the transformer terminal B1 unsoldered as the ground wire will be added later. The red terminals go the transformer connections B2, B3, and B4 (2, 4 or 8 Ohms). Run these wires around the outsides of the output transformers and fix them with cable ties.

After scratching off the paint surrounding the spare hole beside the power supply fixings, secure the solder tag with an M3 screw and nut. Connect a wire from this tag to the earth pin (marked E) on the mains input socket to become the earth tag. Wrap a wire from the earth tag to pin X17 on the power supply board, but leave the earth tag unsoldered as there are earth wires to be added later. Connect points 1 and 4 on the mains switch to the remaining pins on the mains inlet socket, as shown in figure 1 below:

Figure 1. Mains socket switch connections

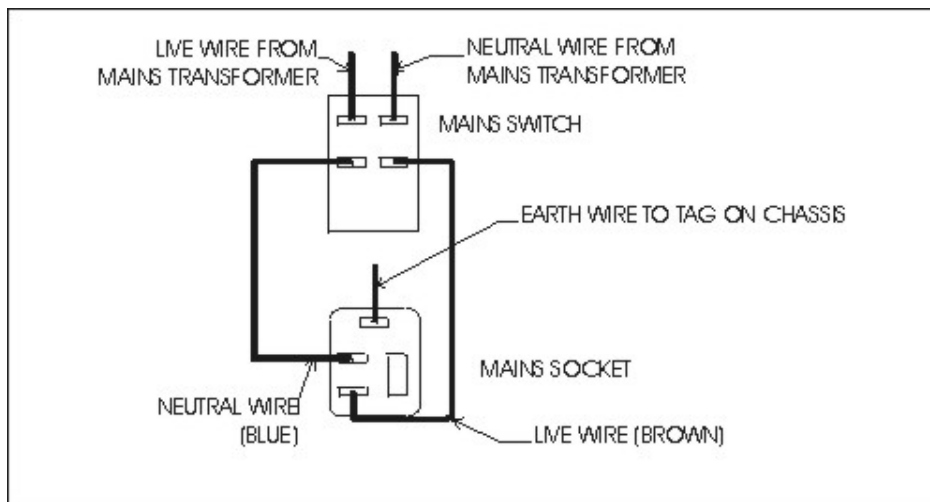

Figure 2 below shows the different windings on the mains transformer, not all of them are used. Connect the mains transformer starting with the primary side that contains two pairs of 115V windings.

For 220V/240V mains:

Solder the grey and white wires together and fold them over to leave them approximately 5cm in length. Seal them with a length of heat-shrink sleeving so that no bare wires are exposed. The brown and blue wires from the transformer solder to points 2 and 5 on the mains switch as shown in the above diagram. Note: the blue wire goes to the left, and the brown to the right when viewed from the front of the amplifier. Cable-tie the four wires together to keep them tidy.

For 110V/120V mains:

Solder the blue and white wires together as one pair, and the brown and grey wires together as the other. Now solder the pairs to points 2 and 5 with the blue/white combination to the left, and the brown/grey to the right when viewed from the front. Cable-tie the four wires together to keep them tidy.

Figure 2. Mains transformer windings

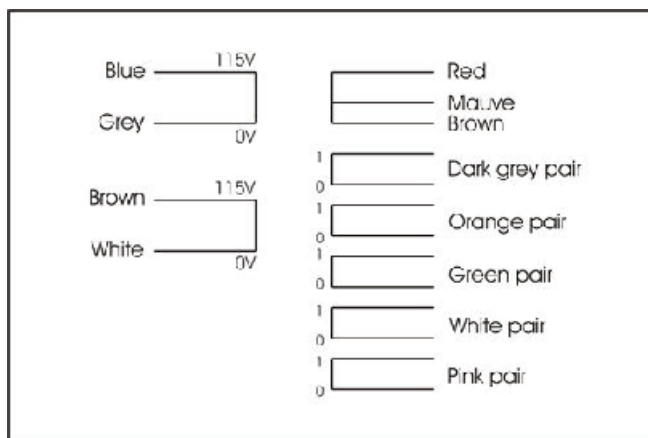

Next connect the high-tension wires, which may be thicker in diameter than the others. The red and the purple go to points X15 and X16 on the power supply board and supply 460V AC from 240V AC mains. It is not necessary to keep them in phase. The brown wire is not used in this amplifier. The rest of the transformer wires connect to the heaters when the amplifier is finally assembled, apart from the white and pink pairs which are not used.

Mounting The Audio PCB In The Front Chassis Panel:

Before the Audio PCB's are fitted, the octal valve bases for the EL34 power valves must be attached to the front chassis panel using two black M3 screws, an M3 nut, and a 12mm stand-off for each base. The two outer valve bases have the spacer on their outer sides, and the two inner valve bases have their spacers on their inner most sides. This is to support the PCBs properly. The valve bases mount directly under the chassis panel with the valve orientation slot to the right of the amplifier when viewed from the front top. Then, using the remaining 12mm stand-off's fix the front row of the PCB to the chassis using M3 countersunk screws in the appropriate holes.

The two PCB's can now be fitted to the front chassis panel. For ease of fitting the screws holding the pillars may need loosening (these are pre-mounted on some chassis).

The EL34 valve bases need connecting to the PCB's. The valve base pins are numbered 1 to 8. **Warning:** be sure to read the numbering correctly as it is easy to make a mistake. Pin 1 must be linked to pin 8 on all four of the EL34 valve bases, and extended to points X1 and X4 on the respective valve bases. For PP mode connect points X13 and X3, to pin 5 on the respective valve bases, although for PSE mode connect X2 instead of X13 so that X2 and X3 are connected to pin 5. The 105R resistors (R53) must be soldered between pins 4 and 6 on each EL34 valve base.

Before the volume pot can be fitted, the paint must be scratched away from the inside of the larger hole in the front panel to enable it to be grounded properly. For volume pot pin numbering please refer to figure 3 below. Connect pins 1 and 4 to ground on the closest PCB (not both) at point X10. The PCB's will be referred to as left and right when looking from the front so that the left PCB drives the left channel, and vice-versa. Terminal 2 on the volume pot connects to point X9 on the right PCB, and terminal 5 connects to point X9 on the left PCB. Connect terminal 3 to input switch S2 terminal 4, and finally connect terminal 6 on the volume pot to input switch S2 terminal 3. The volume knob can now be fitted using a small flat bladed screwdriver.

Figure 3. Volume pot numbering

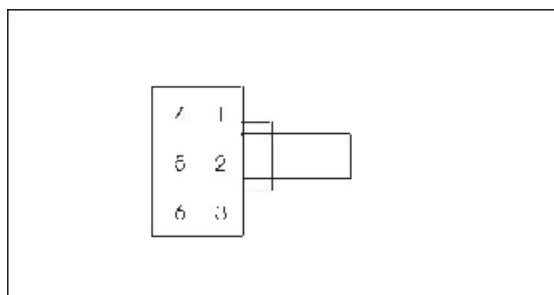

The switches can now be fitted in the two smaller holes in the front panel, although they will be connected up later.

Complete Assembly:

The side panels are fixed to the bottom rear chassis using six M3 screws, but first scratch the paint on the hidden edge to make a continuous earth between all panels. The front chassis is now ready to be fitted to the chassis using six M3 screws.

For PP mode connect point X18 on the power supply board, to points X5 on each of the audio PCBs. If configuring for PSE mode with one power supply board, then wire it for the PP configuration as above. However, if you are configuring for PSE mode with the extra power supply board, then connect points X18 on each power supply board to points X6 on the respective audio PCB.

The ground terminals X12 on the audio PCB's connect to each of the output transformers terminals B1; the ground connection for the speakers. The output transformer terminal B1 can now be soldered but be careful not to heat the tags for prolonged periods as they are plastic and can melt.

A ground wire should also be connected between X12 on the right PCB to the earth tag on the chassis. There should now be three wires to the earth tag; the main earth from the inlet socket, the earth to point X17 on the power supply board, and the earth to the right PCB. If they are all present then the earth tag can be soldered.

To connect the heaters, link the two dark grey wires from the mains transformer to points X7 and X8 on the right PCB, the polarity does not matter. Now link points X7 and X8 on the right PCB to points X7 and X8 on the left PCB respectively, the polarity of this connection is important to stop the heater windings from shorting if both the earths are connected on the PCBs.

To wire the EL34 heaters on the left PCB, the orange pair of wires from the mains toroid are connected to pins 2 and 7 on V2. Then, two wires from pins 2 and 7 on V2 are connected to pins 2 and 7 respectively on V1. For the right PCB the green pair of wires are used and connected in the same way.

The transformer windings that are not used should be cut off and/or insulated using the heat shrink so that none of the windings are touching (they may be useful one day).

Connect a wire from terminal B4 on the output transformers, to points X11 on the corresponding PCBs for the feedback connection. It is a good idea to wire the right PCB first as this is further away and the wire will be longer. Now cut the wire for the left PCB to the same length as the right to give the same feedback path for each channel.

Configuring The Output Transformer For PP Mode:

Figure 4. Output transformer in PP mode

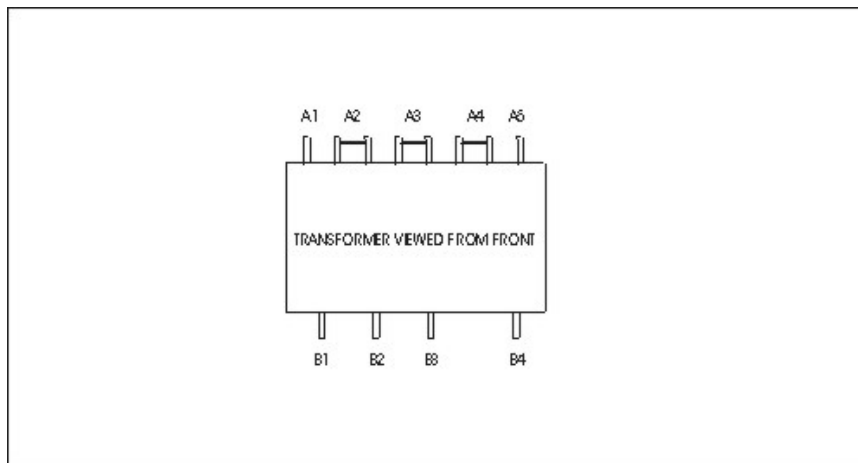

Connect point X5 on each main PCB to its corresponding output transformer terminal A3 (shown on figure 4 above).

For connecting the EL34 valve bases to the output transformers, starting with the left PCB, link a wire from pin 3 on valve base V1, to terminal A1 on the output transformer. Pin 6 on V1 (105R resistor), goes to the transformer terminal A2. Pin 3 on valve base V2 goes to pin A5, and pin 6 goes to terminal A4. The right PCB is connected the same way.

The amplifier is now connected in ultra linear mode. For Triode mode connect pin 6, to A1 and A5 respectively on the output transformer. For Pentode mode connect pin 6 from V1 and V2, to A3 on the output transformer.

Configuring The Output Transformer For PSE Mode:

Figure 5. 2.4K primary for maximum power triode connected

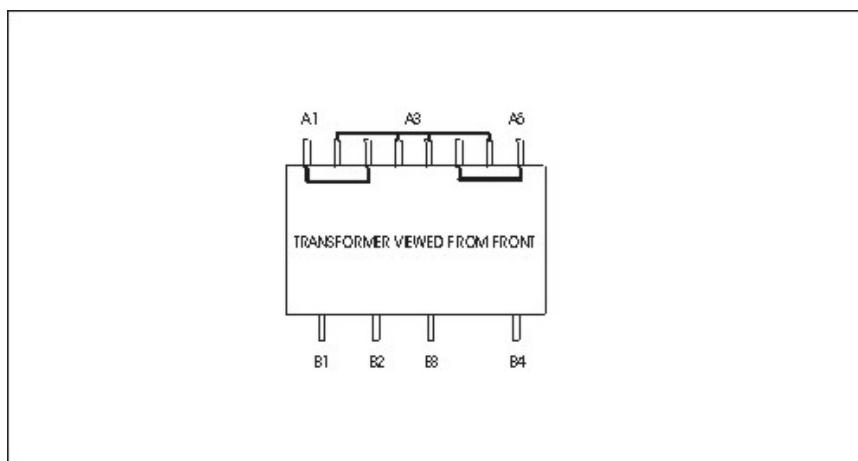
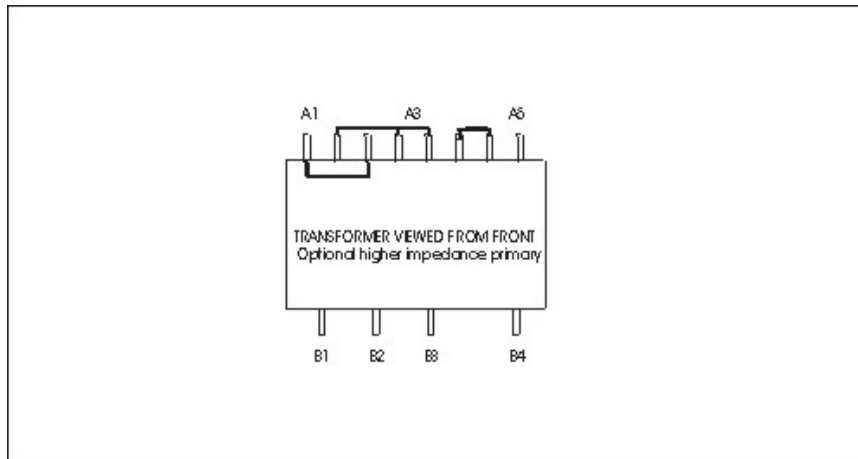

Figure 6. 3.6K primary for lower distortion with better low frequency, but lower output.



Connect up the links as shown in figure 5 or 6 above. Connect point X5 on each main PCB to terminal A5 on the corresponding output transformers. On the left PCB connect pin 3 on both V1 and V2, to A1 on the output transformer. Now connect the two screen grid wires that come from pin 6 on each EL34, to A3 on the left transformer. The EL34's are now connected in parallel. The right channel is wired in exactly the same way.

This is ultra-linear mode. For triode or pentode mode follow similar instructions for the PP transformer connections.

Wiring The Input Connectors And Switches:

Cut the length of screened cable into three equal sections; they should be approximately 470mm each. Now connect the centre wire of the screened cable to the positive terminals as shown in figure 7 below.

Figure 7. Input switch connections from RCA sockets

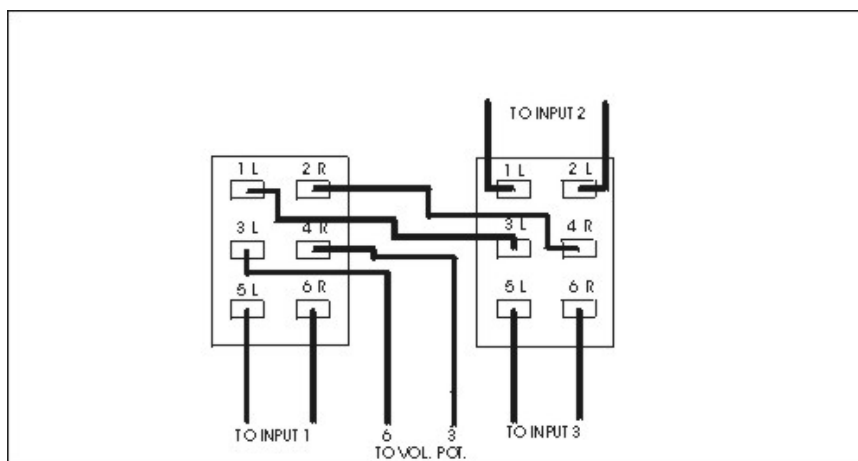

The screening, which is the ground connection for each input, should all be linked to ground point X10 on the left PCB next to the volume pot. Finally, link a wire between point X10 on the left PCB, to X10 on the right PCB.

Checklist:

The valve amplifier should now be fully assembled. Here is a list of items that should be checked **before the amplifier is plugged in:**

1. Check that the earth connections have been soldered from the case to the mains inlet. The resistance between the earth pin of the mains plug and the chassis should be less than 0.5 ohms; generally the resistance of the test wires.
2. Turn the mains switch on and fit the fuse (which should be rated at 250 volts 3.15 amps). Measure the resistance between the earth pin in the mains plug and the other two pins on the mains plug. This resistance should be infinite.
3. Check that the mains transformer wires are secure and wired to the correct places.
4. Check that the output transformers are connected correctly to the speaker terminals and to the audio PCB's and valves.
5. Check that the power supply board is connected to each of the audio PCB's.
6. A visual check is also a good idea to make sure that everything looks safe and correctly connected.

The valve amplifier should not be switched on without the valves plugged in, and without a sensible load connected to the speaker output terminals as this will damage the amplifier. **INSERT THE TUBES AT THIS POINT.**

THE AMPLIFIER CAN NOW BE PLUGGED IN AND TURNED ON.

The following nine voltages should be checked, using a Multimeter, to make sure that the amplifier is operating safely. This should be done with the volume pot turned right down so that the voltages are not affected by the output signal. The voltages can be measured with the amplifier stood up on one end.

WARNING: CARE MUST BE TAKEN WHEN CARRYING OUT THIS PART OF THE PROCEDURE AS THERE ARE DANGEROUS VOLTAGES INSIDE THE AMPLIFIER. IF UNSURE, PLEASE SEEK ASSISTANCE FROM A QUALIFIED ENGINEER.

Please note that these voltages may vary slightly due to variations in the mains supply, and valve and component tolerances. Note: a variation of approximately 10% is acceptable without any detrimental problems.

1. On the power supply PCB measure the voltage between X17 (ground), and X18. For PSE mode this should be approximately 460V DC. For Push Pull this should be approximately 460V DC.
2. The Cathode bias voltage (pin 8) for each EL34 should be approximately 35V DC. This is measured across the 510R 6W resistors, and is relatively important to prove current flow through the valve.
3. The anode voltage for each EL34 should be approximately 430V DC. This is measured between ground and pin 3 of each EL34.
4. The smaller tubes can also be checked top and bottom for bias voltages.

Final Assembly:

Disconnect from the mains.

The last two feet can be fitted to the bottom cover plate using M4 screws and nuts. The holes in some of the cover plates will need drilling out to fit the M4 screw.

Last of all the top cover plate must be fitted. The front of the panel tucks under the front chassis panel and is secured by three M3 screws at the rear. If the top cover does not tuck under the front panel the corners may need trimming off as shown in figure 8 below.

Figure 8. Trimming the top cover panel (side cutters will do)

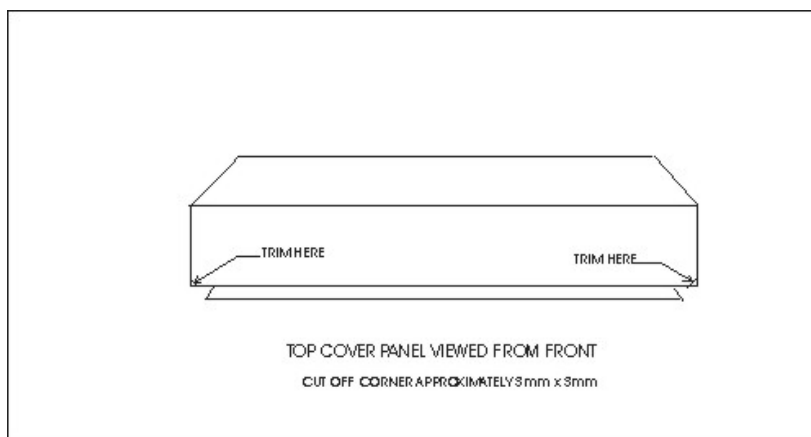

Please note that the amplifier is at all times pure Class-A, and as such will run reasonably hot.

We hope that you enjoy your kit!!!

If you have any technical queries or construction problems please email:

technical@audion.co.uk